

Innovación para el transporte

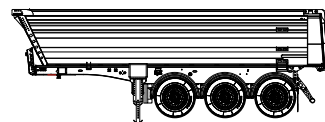

AluHARD[®] 500



ROJO TRAILER

Chasis V

Con un diseño innovador en forma de **V** que se caracteriza por unas vigas principales de una sola pieza, sin uniones y plegadas. Se reduce notablemente la superficie soldada y mejora la resistencia estructural.

Aumentamos la **anchura total del chasis** hasta **1.660 mm** mejorando la estabilidad y el asentamiento de la caja sobre el chasis.

Fabricado en acero de **extra alto límite elástico**, con el que conseguimos un peso inferior a los chasis de aluminio y una resistencia elástica 15 veces superior.

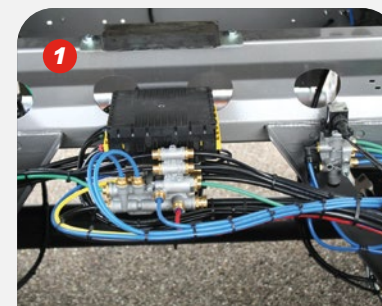
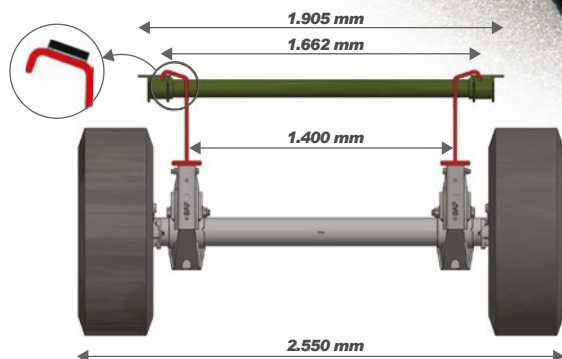

Centralita electrónica



Descenso de la suspensión automático electrónico



Kit asfaltado compatible con todas las extendedoras

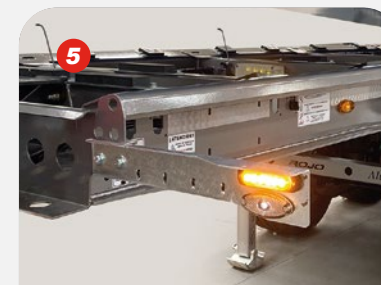

Alarma inclinación lateral



Ejes con suspensión integral y freno de disco

ROJO

AluHARD® 500



Aún más resistente Aún más ligera

Caja

HARDOX® 500 TUF

Fabricada con la última tecnología en metales especiales anti desgaste: **HARDOX 500 TUF**. Un 20% más resistente al desgaste que el tradicional Hard 450. Y un 900% más duradero que el aluminio.



Con un diseño actualizado, más eficiente, conseguimos más resistencia y menos peso.



Doble rigidizador longitudinal



Cierres neumáticos automáticos



Fijación del cilindro a la caja

Opcionales



 Eje autodireccional



 Cobertura de aluminio sobre aletas



 Pareja focos adicionales de marcha atrás (led)



 Caja isotérmica

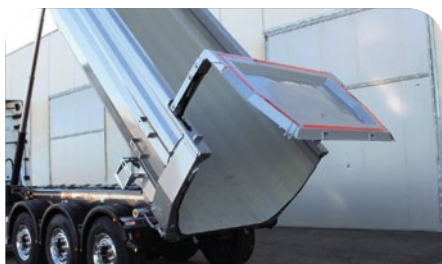

 Puerta hidráulica



 Puerta universal



 Puerta de acero



 Trampilla trasera



 Techo corredero



 Paragolpes subida neumática

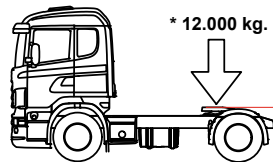
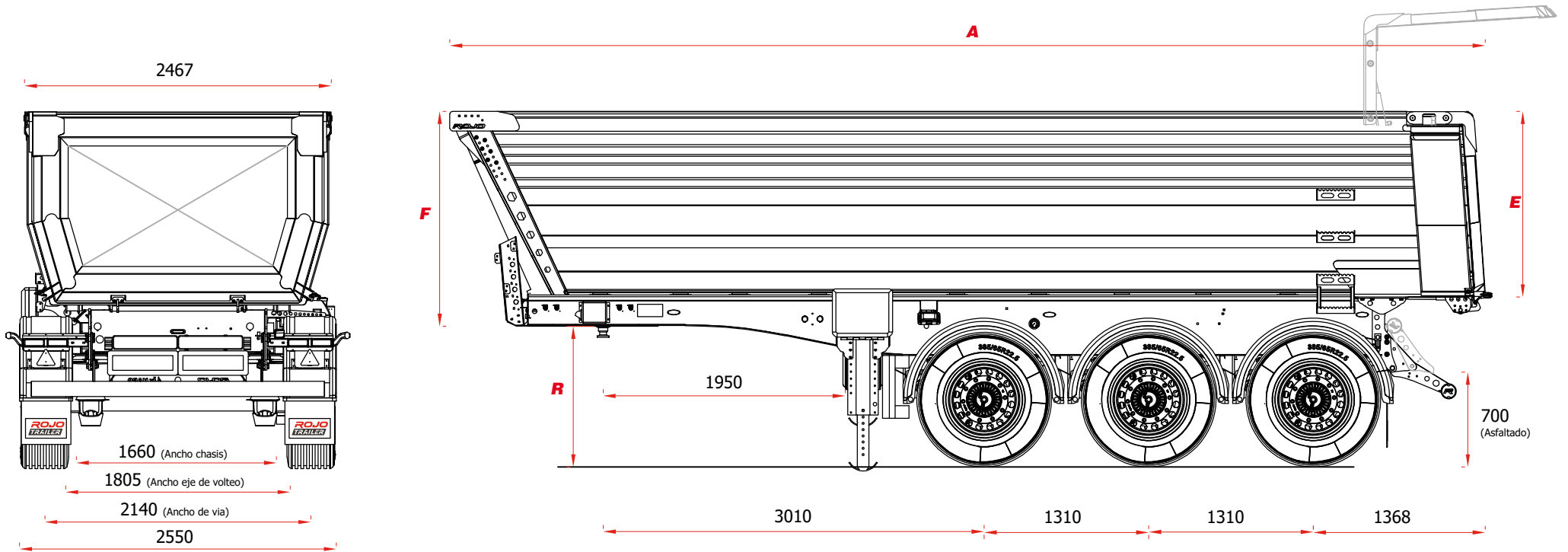

Altura máxima
5ª Rueda
(con carga)*

Modelo suspensión

	X1	X2	X3	X4
R	1.200	1.250	1.300	1.350

	A	E	F	AluHARD® 500
20 m³	8.140	1.270	1.510	4.690 kg
22 m³	8.195	1.380	1.620	4.750 Kg
24 m³	8.235	1.470	1.710	4.760 kg
26 m³	8.285	1.580	1.820	4.860 kg
26+2 m³	8.340	1.680	1.920	4.930 kg



ROJO TRAILER S.L.

Pol. Ind. Alto Milagros s/n
09460 Milagros (Burgos) ESPAÑA
Tel. (+34) 947 546 411

www.rojotrailer.com



Manufactured in the
European Union